

AIR VIBRO HAMMER

12 INCH AIR VIBRO HAMMER

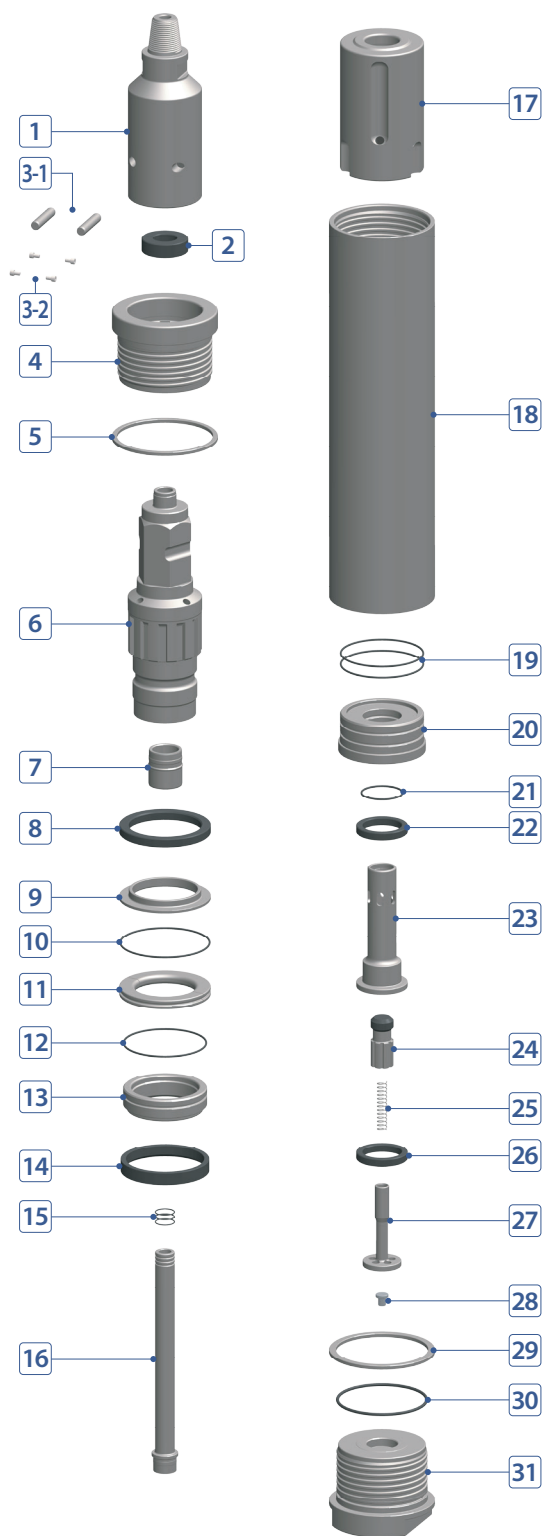

COMPONENT PART



No.	DESCRIPTION	Q'TY	PART #
1	Cushion Device	1	B050-07-C21ARP
2	Buffering	1	B050-07-C07000
3-1	Locking Pin	2	B050-07-C23000
3-2	Wrench Bolt	4	B050-07-C22000
4	Chuck	1	B050-07-A41000
5	Chuck Washer	1	B050-07-A39000
6	Flange Joint	1	B050-07-A67000
7	Foot Valve	1	B050-07-A71000
8	Chuck Buffering	1	B050-07-A70000
9	Chuck Buffering Sleeve	1	B050-07-A66000
10	Bit Retainer O-Ring	1	B050-07-A37000
11	Bit Retainer	1	B050-07-A36000
12	Bearing O-Ring	1	B050-07-A32000
13	Bearing	1	B050-07-A31000
14	Piston Stop Ring	1	B050-07-A28000
15	Inner Tube O-Ring	3	B050-07-A65000
16	Inner Tube	1	B050-07-A63000
17	Piston	1	B050-07-A26000
18	Wear Sleeve	1	B050-07-A25000
19	Air Tube Guide O-Ring	2	B050-07-A20000
20	Air Tube Guide	1	B050-07-A19000
21	Air Tube Guide Inner O-Ring	1	B050-07-A61000
22	Tube Buffering	1	B050-07-A21000
23	Tube	1	B050-07-A64000
24	Air Check Valve	1	B050-07-A09000
25	Air Check Valve Spring	1	B050-07-A10000
26	Tube Buffering	1	B050-07-A21000
27	Air Guide	1	B050-07-A11000
28	Plug	1	B050-07-A60000
29	Back Head O-Ring	1	B050-07-A03000
30	Back Head Washer	1	B050-07-A02001
31	Back Head	1	B050-07-A01002

HAMMER SPECIFICATIONS

Length (w/o drill bit)	62"	1,569 mm
Outside Diameter	11"	272 mm
Weight	1,095 lbs.	497 kg
Piston Weight	174 lbs.	79 kg
Connection	Std. 3-1/2" API Reg Pin	